

PRECISION DIGITAL

Water & Wastewater Instrumentation Solutions Guide



Open Channel Flow



Storage Tank Volume



Pump Alternation Control



Filter Console Displays



Aeration Basin Level



Digester Temperature



Pump Station Level



Gas Detection Monitor



Filter Effluent Turbidity



Backwash Flow Rate

Enhance Your 4-20 mA Loop With a Precision Digital Meter or Controller

- ✓ Built-in power supply for transmitter
- ✓ Relays for control & alarm
- ✓ Local display for just about anywhere

PRECISION DIGITAL CORPORATION *Since 1974*

INTELLIGENT MONITORING & CONTROL

Order from: **C A Briggs Company**

622 Mary Street; Suite 101; Warminster, PA 18974

Phone: 267-673-8117 - Fax: 267-673-8118

Sales@cabriggs.com - www.cabriggs.com



www.CABriggs.com

PRECISION DIGITAL: Digital Displays and Controllers for the Water & Wastewater Industry

This Solutions Guide will show you how your colleagues in the water and wastewater industry have used Precision Digital products to optimize their operations. They have used our products to:

- **Upgrade their filter control consoles** with digital displays that can be read from three times the distance as the original meters
- **Monitor** such parameters as digester temperature, digester level, and open channel flow
- **Control and alternate** pumps in lift station wet wells
- **Totalize** influent and effluent flow with resettable and non-resettable totals
- **Add display and alarm capabilities** to gas detection systems
- **Wirelessly transmit 4-20 mA signals** from the field to the control room

With over 45 years of experience, we have developed a product line with the features customers in the water and wastewater industry want:

- UL listing for electrical safety
- Wide operating temperature range
- Sunlight readable displays for outdoor use
- NEMA 4X protection for installation in wet and dirty areas

This Solutions Guide will go into more detail about specific product features, but if you need something you don't see, please feel free to call us at **1-800-343-1001**.





Table of Contents

- **04 What's New**
- **06 Success Stories**
 - Level measurement
 - Filter console upgrades
 - Influent flow
 - Digester temperature
 - Turbidity displays
 - Open channel flow
 - Pump speed
- **20 Fundamentals of 4-20 mA Current Loops White Paper**
- **24 Multivariable Control**
 - Lift station control
 - Multi-pump control and alternation
- **28 Industrial Wireless**
 - Point to point or multi-point
 - Make your 4-20 level transmitter a wireless device
- **30 Level**
 - Pump control & alternation of up to 8 pumps
 - Dual-scale display of level in height and volume
 - Decimal and feet & inches display capabilities
- **34 Flow**
 - Display flow rate and total at the same time
 - 4-20 mA or pulse inputs
 - Open channel flow
- **35 Other Applications**
 - Temperature
 - Gas detection
 - Display & alarm system

What's New at Precision Digital

Display, Control, & Alarm of Multiple 4-20 mA, Pulse, and Modbus Inputs with the ConsoliDator+



 ConsoliDator+



NEW
Modbus Client Capabilities
Display up to 99 Modbus Inputs



NEMA 4 & 4X Enclosures for ConsoliDator+

Plastic NEMA 4X and steel NEMA 4 enclosures are available to conveniently mount the ConsoliDator+ to a wall.

ConsoliDator+ PD9000 Multivariable Controller

- NEMA 4X panel or field mount
- Numeric & bargraph color display
- **NEW** Modbus Client, Server, Snooper, and Spoofer Modes
- (20) Screens with up to (8) PVs each
- Isolated 24 VDC transmitter power supplies for all analog inputs & outputs
- -40 to 60°C operating temperature
- Multi-pump alternation control or simple on/off control
- Pulse and analog input flow rate / total / grand total capability

More Inputs, Outputs, Communication Options

- Up to (28) 4-20 mA Isolated Inputs or Up to (28) Pulse Inputs
- Up to (25) 10 Amp Form C Relays (With Eight Analog or Pulse Inputs)
- Up to (25) Isolated 4-20 mA Outputs (With Eight Analog or Pulse Inputs)
- **NEW** Modbus Client, Server, Snooper, and Spoofer Modes
- Up to (99) Modbus inputs & outputs
- Display up to 160 Values
- RS-485 Modbus RTU standard & Ethernet Modbus TCP/IP optional
- Micro-USB for configuration with FREE ConsoliDator+ software



Sun Hood & Light / Horn for ConsoliDator+

The PDA9000SH provides shade for the ConsoliDator+ when it is mounted in direct sunlight.

The PDA/MOD-LH provides visual and audible alarm indication.



ConsoliDator+ Programming Software

FREE programming software available for download. Configure inputs, outputs, alarms, and timers.

Learn more at predig.com/PD9000



**MOD-LH
Light / Horn
Package**

Helios, ConsoliDator+, and Enclosures can be equipped with a Light / Horn and Reset Button for audible and visual ways to indicate alarms. Available in various color combinations.

Cool Accessories For Your Bench & Toolbox



**PD9502
\$99**

**Low-Cost
Signal Generator**

A compact, simple to use 4-20 mA or 0-10 VDC signal generator.

- Wall Plug & Signal Cables Provided
- 4-Digit LED Display
- One-Turn Adjustment Knob
- 15-27 VDC power or USB Power Bank



**PD9501
\$599**

**Multi-Function
Calibrator**

Features a variety of signal measurement and output functions.

- Measure & Source T/Cs, RTDs, Ohms, Current, Voltage
- 24 V Power to Drive the Transmitter
- Auto Stepping & Auto Ramping



**PD420
\$149**

**4-20 mA Set-Point
Generator**

Panel mount device generates a 4-20 mA signal to input to another device.

- 4-20 mA or 3-21 mA Output Ranges
- Built-in Dial for Changing Output
- Coarse or Fine Set Point Adjustment
- 15-30 VDC Power Requirement



**PDA1001
\$19**

USB Power Bank

A portable USB power bank that can conveniently provide power to the PD9502.

- Provide power to the PD9502 for 6+ hours
- USB to Micro USB cable included

See more at predig.com/whatsnew

Success Stories

Level in Feet and Inches at Water Booster Pump Station

Application

A water booster pump station had level transmitters with displays that were difficult to read. In addition, the readings needed to be displayed in feet and inches, not a decimal.

Solution

Two PD6001 feet and inches level meters were installed in a PDA3411 enclosure. These display the tank level in feet, inches, and 8ths of an inch, the way the customer prefers to display their level measurements.



Clarifier Level Measurement

Application

An upgrade was needed to replace two old level transmitters mounted in distribution channels off their primary and secondary clarifiers. The old transmitters had remote displays that provided local indication, however the new ones did not have any level indication. This was a problem because the customer wanted to read the levels above the hatch doors.

Solution

Two PD6000 meters were used to provide local level indication at the hatch doors as well as power for the new level transmitters, relays to control the pumps, and a bright dual-line display of level in the clarifier channels.



Sump Level Monitoring and Pump Alternation

Application

A waste sump at a pharmaceutical company had a guided wave level transmitter. Pump alternation was needed and visual and audible alarm indication.

Solution

The Helios PD2-6000-6H7 powers the level transmitter, performs pump alternation, and the red light and horn provide the high/low level alarm indications.





Wastewater Treatment Plant Tank Side Level Measurement

Application

A wastewater treatment plant installed a level transmitter without a display on top of the tank. A tank side display of the level was needed. Audible and visual alarm indications were also required for high or low level conditions.

Solution

A PD6001 feet and inches level meter mounted in a PDA2301 enclosure was installed to monitor the tank level. In addition, a MOD-LH light/horn and silence button were added for visual and audible indication of alarms. The MOD-LH option also provided the holes drilled in the enclosure for easy mounting of the light/horn and silence button.

The PD6001 displays the tank level in feet, inches, and 16th of an inch. The PD6001 relays trigger the light and horn during high and low level alarm conditions.

Volume Measurements at Water Treatment Plant

Application

A Florida water treatment plant was using older ultrasonic level transmitters to measure and display the volume of several tanks. Their LCD readouts became faded from sun exposure over years of use.

Solution

Trident X2 meters were installed to display the volume in six tanks. The Trident X2's bright 1.2" high LED display is readable from up to 30 feet away, and the relays provide high level alarms for three bulk storage tanks.



Clearwell Level Instrumentation at Water Treatment Plant

Application

Clearwell level control instrumentation was in need of an update. The old analog pump controller had stopped working.

Solution

A PD6000-6R7 pump controller mounted in a PDA2811 NEMA 4X enclosure replaced the old controller. The PD6000 displays level and performs lead-lag pump alternation for their 3 pumps.

Before



After



Polymer Tank Level at Wastewater Treatment Plant

Application

A wastewater treatment plant had two polymer tanks with radar level transmitters. Local indication of the polymer level was needed to make sure proper mixing was occurring in the tanks.

Solution

PD6000 meters were provided to read out the polymer level in inches. The PD6000 meters were mounted in PDA2811 NEMA 4X enclosures above each tank for a local indication of the polymer levels.



Chemical Storage Tank Volume

Application

Ultrasonic transmitters were being used at a wastewater treatment plant to measure the volume in two sodium hypochlorite tanks. The plant needed a local display of the gallons in the tank, an isolated 4-20 mA signal retransmitted to their control room, and a NEMA 4X enclosure for the display meters.

Solution

Two PROVu PD6000-6R3 meters were provided to display the volume in gallons of the two sodium hypochlorite tanks and the retransmit of the 4-20 mA signal. A PDA2812 NEMA 4X enclosure was used to house these two meters. An aluminum sulfate tank was added later and another PD6000-6R3 meter was added to display the gallonage. This meter was put into the PDA2811 enclosure that holds a single PROVu meter. Precision Digital offers plastic, steel, and stainless steel enclosures that can house up to 10 meters.



Ammonia Tanks

Application

Three ammonia storage tanks at a water treatment plant, each with level and pressure transmitters, required tank side indication of both measurements.

Solution

PD6602 loop-powered meters were installed to indicate level in feet and pressure in PSI. The dual-line 14-segment display provides clear indication of PVs while the NEMA 4X front provides outdoor protection.

Wireless Monitoring of Level and Flow Measurements

Application

A wastewater treatment plant was measuring the levels in two sodium hypochlorite tanks and flow from an influent pipe. These signals needed to get across the plant to their SCADA system.

Solution

Each level transmitter is connected to a PDW90-FN field unit that wirelessly sends the 4-20 mA signals back to a PDW90-BA base station in the plant's office. Two PD6000 meters display the tank levels and transmit the 4-20 mA signals to their SCADA system. The flow meter is connected to another PDW90-FN field unit that wirelessly transmits the 4-20 mA signal to the same PDW90-BA base station in the plant's office.



Influent Open Channel Flow

Application

Influent flow was being measured by an ultrasonic transmitter in a Cipoletti weir. The original display could not be read in direct sunlight. A brighter display was needed.



Solution

A PD6200-6H5 meter was installed with SunBright LEDs, two relays and an isolated retransmit of the 4-20 mA. Flow rate is displayed on the top line and total on the bottom line.



Effluent Open Channel Flow

Application

Local and easy to access indication was needed for an ultrasonic transmitter measuring effluent flow through a Parshall flume at a wastewater treatment plant.



Solution

A PD6622 loop-powered meter mounted in a PDA2811 NEMA 4X enclosure provides an eye level display of both flow rate and totalization of effluent from the plant.



Influent Water Level Measurement in Feet and Inches

Application

Two aeration basins were using submersible pressure transmitters to measure level. A remote indication of the levels in feet and inches was needed in the wastewater treatment plant shop.

Solution

PD6001 meters were installed to display the level of aeration basin 9-A and 10-A in feet and inches. PDA2301 enclosures were used to mount the meters. The PD6001 relays were used to turn on tri-colored lights for visual indication of high and low level alarms.



Effluent Flow

Solution

Though the application did not require an explosion-proof meter, the customer chose the PD6820 for its rugged NEMA 4X/IP66 enclosure. The top line is displaying million gallons per day and the bottom line is displaying total gallons.

Control Room Console

Solution

Sabre PD603 meters display suction and discharge pressures from pumping stations, and discharge flow rates. Dual line PD6000 meters display the level of water towers as an elevation on the top line and are scaled on the bottom line to read as tank level. The inset PD6200 is displaying backwash flow rate on the upper line and totalized flow on the bottom line.



Digester Temp



Solution

The standard display size Trident meter is displaying sludge outlet temperature on Digester 10.

Digester Level



Solution

A Loop Leader is displaying Digester level in engineering units as indicated by "Feet" on the display line 2. No additional power is required for meter.

Pump Speed



Solution

The customer really appreciated being able to read the Trident X2's large display from much farther away than the previous meters.

Soda and Lime Pump Control Panel

Solution

Eight PD765 Trident X2 meters are used to indicate the motor speed adjustment of pumps in sedimentation tanks in a water treatment plant.



Lead-Lag Pump Alternation Control

Application

Two 10 MGD pumps are installed in a 50 foot well and need to alternate operation for even pump wear. The pipe out of the well can support a maximum flow rate of 12 MGD so it is not possible to Operate both pumps at the same time even at partial flow conditions from one of the pumps. In addition, the system needs to provide a high-level alarm to indicate that a pump is failing.

Solution

The solution requires five relays so a Precision Digital PD6000-6R4 with four internal relays and a PDA1004 4-relay expansion module was chosen. Two of the relays are programmed for pump alternation, two relays are programmed for high level alarm and one is programmed to turn on a pump failure alarm.

Relay	Action	Set Point	Action	Reset Point
Alternating Relay # 1	Pump on Level	40 Feet	Pump Off Level	5 Feet
Alternating Relay # 2	Pump on Level	49 Feet	Pump Off Level	5 Feet
High Alarm Relay # 3	Alarm on Level	45 Feet	Alarm Off Level	5 Feet
High Alarm Relay # 4	Alarm on Level	45 Feet	Alarm Off Level	5 Feet
High Alarm Relay # 5	Alarm on Level	45 Feet	Alarm Off Level	5 Feet

Operation

- Normal Condition Pump Alternation
 - When water in the well reaches 40 feet, Alternating Relay 1 will energize, turning on Pump 1.
 - When the water in the well is lowered to 5 feet, Alternating Relay 1 will de-energize, turning off Pump 1.
 - When the water in the well reaches 40 feet again, Alternating Relay 2 will energize, turning on Pump 2. This process repeats, alternating between Alternating Relay 1 and 2, each time the level reaches 40 feet, and then lowers to 5 feet.
- In the Case of a Failing Pump
 - If one pump is unable to keep up, and the level reaches 45 feet, High Alarm Relay 3 and 4 both energize. This switches power from whatever Pump would normally be on, to the other pump.
 - When the level reaches 5 feet, Relay 1 through 4 all reset.
 - The alternating relay cycle continues as normal; with the power switching to the other pump anytime one of the pumps cannot keep the level below 45 feet In the Case of Neither Pump Keeping Up
- If neither pump can keep the water from rising to 49 feet, both Alternating Relays will energize, as will both High Alarm Relays. This will turn on both pumps.
- Alarm/Pump Failure Alarm
 - The use of a relay expansion module increases the number of relays available to 8. In this case, Relay 5 is used as a high alarm that triggers at 45 feet to alert offsite operators that there is a problem at the well.

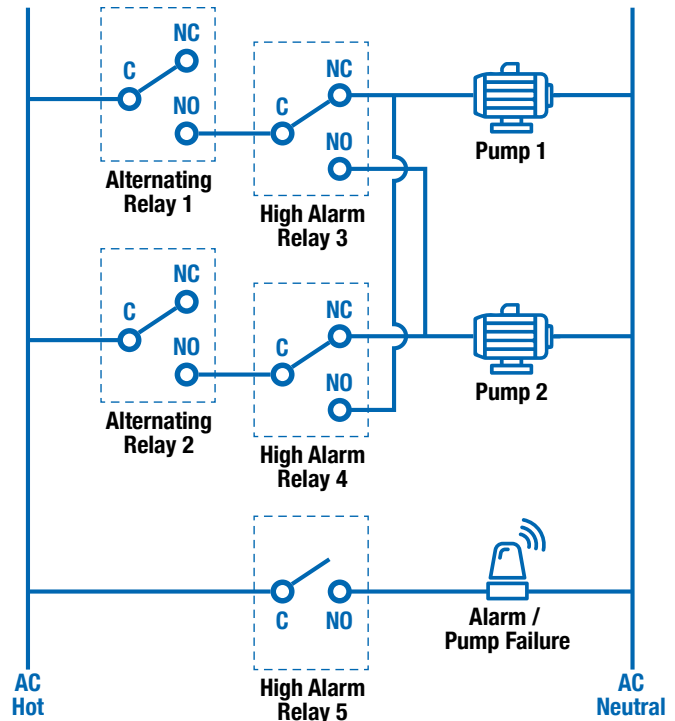

Filter Control Console Upgrades

Application

Filter control consoles had several older display meters that were hard to read.

Solution

The PD765 Trident X2 1/8 DIN digital panel meter is a great replacement for older, hard to see digital panel meters on filter control consoles. The PD765 Trident X2 features a 1.2" (30.5 mm) display that is typically more than twice the size of older meters with displays of 0.56" (14.2 mm). The Trident is UL Listed and features a NEMA 4X front panel.







Back to Basics: The Fundamentals of 4-20 mA Current Loops

In the world of process control, there are a myriad of different types of process inputs. Thermocouples and RTDs provide direct temperature reading while digital signals such as Modbus® provide exacting control over process variables and display. Analog signals, where information about the process is transmitted via varying amounts of voltage or current, are the predominant type of input in industries requiring process control today. Of all possible analog signals that can be used to transmit process information, the 4-20 mA loop is, by far, the dominant standard in the industry.

As major as the 4-20 mA loop standard has become in the process control industry, many do not understand the fundamentals of its setup and use. Not knowing the basics could potentially cost you money when it comes time to make decisions about process display and control. Having a grasp on the history, workings, pros and cons of the 4-20 mA loop will help you to understand why it is the dominant standard for the industry and allow you to make informed decisions about your process control.



A Little Bit of History

Before the advent of electronic circuitry, process control was a wholly mechanical endeavor. Facilities used pneumatic control signals

where controllers were powered by varying pressures of compressed air. Ultimately, air compression of 3-15 psi became the standard for a few reasons:

- It is very expensive to engineer systems detecting pressure signals under 3 psi
- Signals below 3 psi would be unrecognizable
- Easier to differentiate a live zero (3 psi) signal from a failure in the system (0 psi)

In the 1950s, as electronic systems became less expensive, current input became the preferred and more efficient process control signal. The 4-20 mA range later became the standard for similar reasons as 3-15 psi did.

How Does a 4-20 mA Current Loop Work?

In order to understand what a 4-20 mA direct current (DC) loop is and how it works, we will need to know a little bit of math. Don't worry; we won't be delving into any advanced electrical engineering formulas. In fact, the formula we need is relatively simple: $V = I \times R$. This is Ohm's Law. What this is saying is that the voltage (V) is equal to the current (I) multiplied by the resistance (R) ("I" stands for Intensité de Courant, French for Current Intensity). This is the fundamental equation in electrical engineering.

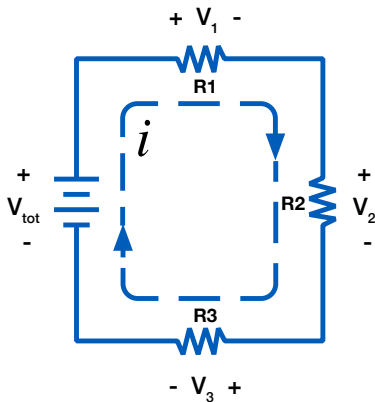

Figure 1. Simple DC Circuit

Consider the simple DC circuit shown on Figure 1, consisting of a power supply and three loads. A current loop requires voltage to drive the current. This is provided by the power supply, with the voltage of the supply labeled as V_{tot} . Current

then flows through the loop, passing through each load. The voltage drop at each load can be calculated from Ohm's Law. The voltage drop V_1 across R_1 is:

$$V_1 = I \times R_1$$

Voltage Current Resistance

Figure 2. Ohm's Law

Every element in the loop either provides voltage or has a voltage drop. However, the current, "I" is the same everywhere in the loop. This is the critical principle of the 4-20 mA loop. Current is the same in all places throughout the loop. It may be difficult to understand why the current remains constant, so consider your home's water system as a comparison. There is a certain amount of pressure in the water pipes pushing the water towards your house.

Voltage, in a similar fashion, acts as a pressure, pushing current through the circuit. When a tap inside your home is turned on, there is a subsequent flow of water. The flow of water is analogous to the flow of electrons, or current. The ability of the pressure to push the water through the pipes is limited by bends and restrictions in the pipe. These restrictions limit the amount of flow in the pipe, similar to how a resistor limits the current. The flow through the pipe, and likewise the current through the wire, remains constant throughout the system, even though pressure, and likewise voltage, will drop at various points. This is why using current as a means of conveying process information is so reliable.

Basic Current Loop

- V_{tot} = Power Supply
- Multiple Resistances / Loads (R_1, R_2, R_3)
- Multiple Voltage Drops (V_1, V_2, V_3)
- Current the Same Everywhere

Water Flow Analogy

- Voltage = Pressure
- Loads = Flow Restrictions
- Current = Flow

Figure 3. Current / Water Flow Analogy

Components of a 4-20 mA Current Loop

Now that you have an understanding of how and why current is used, you can begin to understand what exactly the loop is for.

1. Sensor

First, there needs to be some sort of sensor which measures a process variable. A sensor typically measures temperature, humidity, flow, level or pressure. The technology that goes into the sensor will vary drastically depending on what exactly it is intended to measure, but this is not relevant for this discussion.

2. Transmitter

Second, whatever the sensor is monitoring, there needs to be a way to convert its measurement into a current signal, between four and twenty milliamps. This is where a transmitter will come into play. If, for instance, a sensor was measuring the height of a fifty foot tank, the transmitter would need to translate zero feet as the tank being empty and then transmit a four milliamp signal. Conversely, it would translate fifty feet as the tank being full and would then transmit a twenty milliamp signal. If the tank were half full the transmitter would signal at the halfway point, or twelve milliamps.

3. Power Source

In order for a signal to be produced, there needs to be a source of power, just as in the water system analogy there needed to be a source of water pressure. Remember that the power supply must output a DC current (meaning that the current is only flowing in one direction).

There are many common voltages that are used with 4-20 mA current loops (9, 12, 24, etc.) depending on the particular setup. When deciding on what voltage of power supply to use for your particular setup, be sure to consider that the power supply voltage must be at least 10% greater than the total voltage drop of the attached components (the transmitter, receiver and even wire). The use of improper power supplies can lead to equipment failure.

4. Loop

In addition to an adequate VDC supply, there also needs to be a loop, which refers to the actual wire connecting the sensor to the device receiving the 4-20 mA signal and then back to the transmitter. The current signal on the loop is regulated by the transmitter according to the sensor's measurement. This component is typically overlooked in a current loop setup because wire is so intrinsic to any modern electronic system, but should be considered in our exploration of the fundamentals. While the wire itself is a source of resistance that causes a voltage drop on the system, it is normally not a concern, as the voltage drop of a section of wire is minuscule. However, over long distances (greater than 1,000 feet) it can add up to a significant amount, depending on the thickness (gauge) of the wire.

5. Receiver

Finally, at someplace in the loop there will be a device which can receive and interpret the current signal. This current signal must be translated into units that can be easily understood by operators, such as the feet of liquid in a tank or the degrees Celsius of a liquid. This device also needs to either display the information received (for monitoring purposes) or automatically do something with

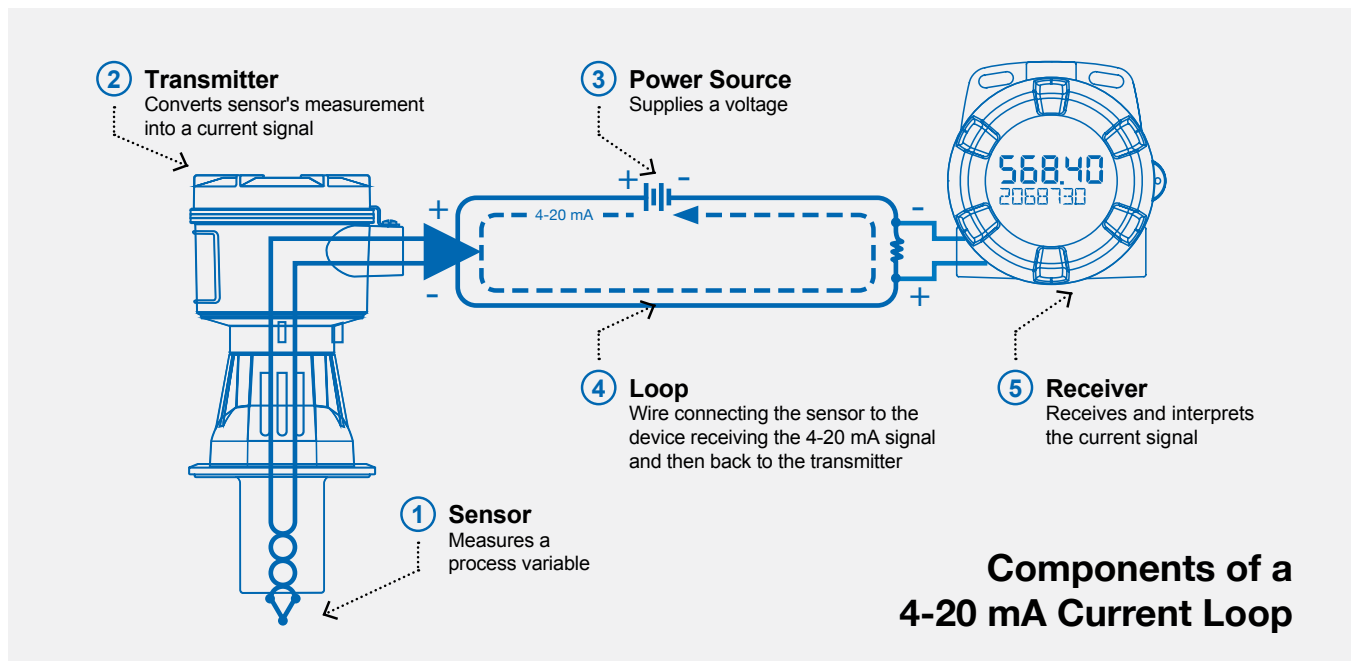

Figure 4. Components of a 4-20 mA Current Loop

that information. Digital displays, controllers, actuators, and valves are common devices to incorporate into the loop.

These components are all it takes to complete a 4-20 mA current loop. The sensor measures a process variable, the transmitter translates that measurement into a current signal, the signal travels through a wire loop to a receiver, and the receiver displays or performs an action with that signal.

Pros & Cons of 4-20 mA Current Loops

Part of the challenge of working in an industry which requires process control is determining if the pros outweigh the cons. Making the right decision can save both time and money.

Pros

- The 4-20 mA current loop is the dominant standard in many industries.
- It is the simplest option to connect and configure.
- It uses less wiring and connections than other signals, greatly reducing initial setup costs.
- Better for traveling long distances, as current does not degrade over long connections like voltage.
- It is less sensitive to background electrical noise.
- Since 4 mA is equal to 0% output, it is incredibly simple to detect a fault in the system.

Cons

- Current loops can only transmit one particular process signal.
- Multiple loops must be created in situations where there are numerous process variables that require transmission. Running so much wire could lead to problems with ground loops if independent loops are not properly isolated.
- These isolation requirements become exponentially more complicated as the number of loops increases.

Summary

The 4-20 mA current loop is the prevailing process control signal in many industries. It is an ideal method of transferring process information because current does not change as it travels from transmitter to receiver. It is also much simpler and cost effective. However, voltage drops and the number of process variables that need to be monitored can impact its cost and complexity. By knowing these fundamentals you will be able to make more informed decisions about process control in your facility which could affect your bottom line.

Featured Products



PD9501 Multi-Function Calibrator

Features a variety of signal measurement and output functions.



PD9502 Low-Cost Signal Generator

A compact, simple to use 4-20 mA or 0-10 VDC signal generator.



PD420 4-20 mA Set-Point Generator

Panel mount device generates a 4-20 mA signal to input to another device.



PD6600 Loop Leader Series

Loop-powered panel meters for safe and hazardous areas with 2 solid state relays and 4-20 mA output options.

Multivariable Control

Lift Station Control

Lift stations are used to transfer waste from where it is created to where it can be treated. Multiple pumps are often used to meet capacity requirements and provide system redundancy. Multiple level technologies ensure measurement reliability during interference events. Proactively detecting maintenance issues on these pumps ensures minimal downtime. Because these sites are rarely manned, communication to a central control station and automatic alarm alerts are mandatory.

When personnel do arrive on site, they must be made aware of any hazardous gases present in the area. Flow monitoring gives the treatment plant visibility on what is coming before it arrives. All of the sensors, control logic and communication requirements for lift station operation can be consolidated into one user-friendly device, the ConsoliDator+ multivariable controller. It provides clear process visibility, simple operation and dependable reliability.

Features

- Configurable I/O
- Multi-pump control with alternation
- Track pump run time and cycle count
- Pump bearing temperature, vibration, seal leak and current draw alarms
- Pump protection with low level and flow switches
- Gas detection and exposure time
- Modbus TCP/IP with assignable IP address

Model:	
PD9000-GP-8PI-16AI-5RY-E	
—	Card 1: (4) Pulse/Switch Inputs
—	Card 2: (4) Pulse/Switch Inputs
—	Card 3: (4) 4-20 mA Inputs
—	Card 4: (4) 4-20 mA Inputs
—	Card 5: (4) 4-20 mA Inputs
—	Card 6: (4) 4-20 mA Inputs
—	Card 7: (5) Relay Outputs
—	Standard: (4) Digital Outputs
—	Optional: (1) Modbus TCP/IP

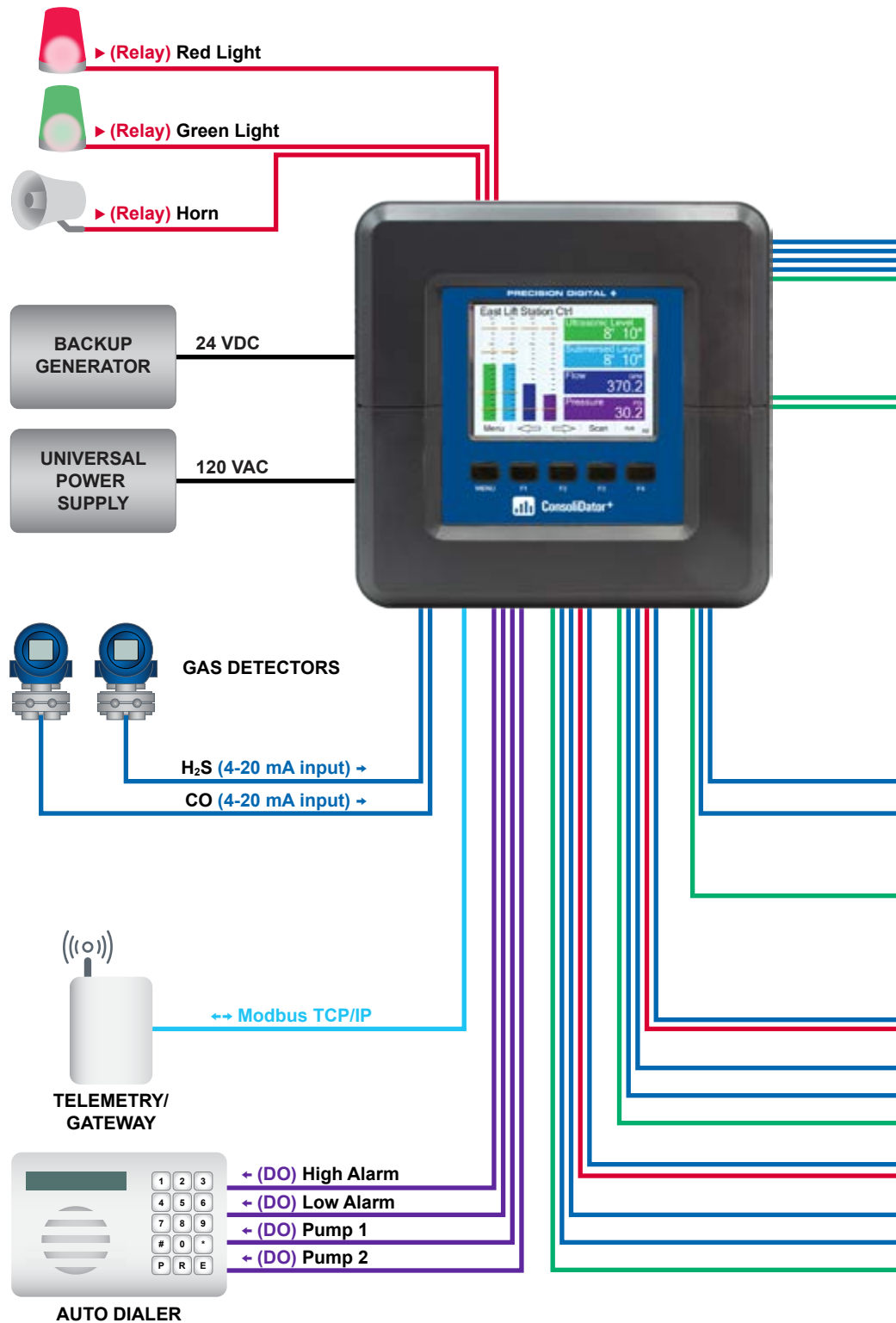

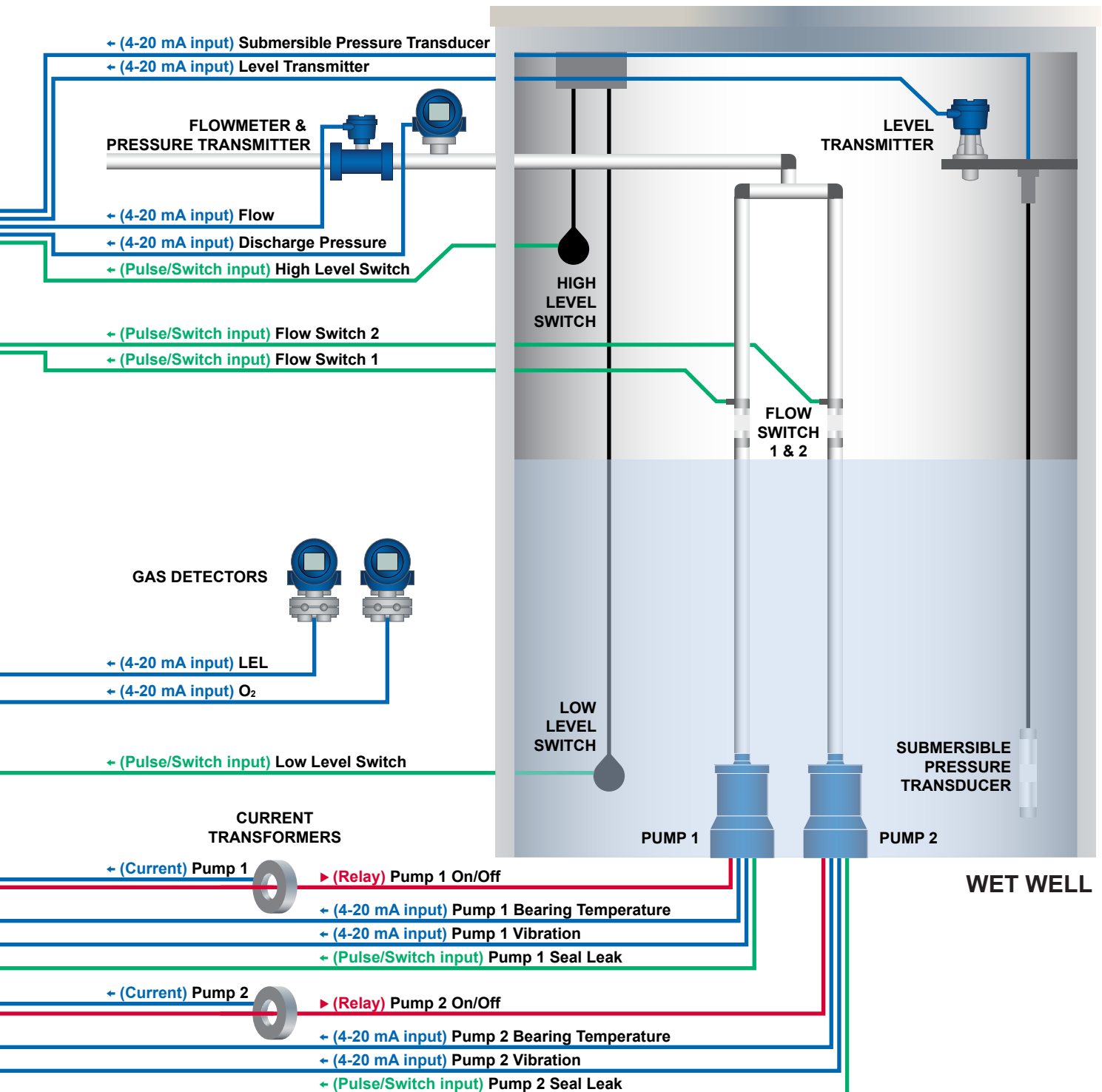

Multi-Pump Control and Alternation

Sodium hypochlorite is a common chemical used for disinfection of wastewater after exiting sand filters. Some plants generate their own sodium hypochlorite by passing an electric current through a solution of salt and water. Sodium hypochlorite in the clean water is then neutralized before it leaves the plant by adding sodium bisulfite.

The brine, sodium hypochlorite, and sodium bisulfite are kept in sumps and storage tanks. Instrumentation is used to control the level of these chemicals and pump them from their storage tanks to the wastewater processes.

A PD9000-GP-8AI-25RY ConsoliDator+ monitors the levels and performs pump control for all these tanks and sumps. All 4-20 mA inputs from the level transmitters are isolated and powered by the ConsoliDator+. Twenty four 10 Amp SPDT relays provide high and low level alarms for each tank, and perform pump alternation for two pumps per tank. Digital outputs are used to alert plant personnel of any alarm conditions by turning on a red light and an 85 dB horn. All other data from the ConsoliDator+ is sent to the plant's Operations Center by Ethernet Modbus TCP/IP.

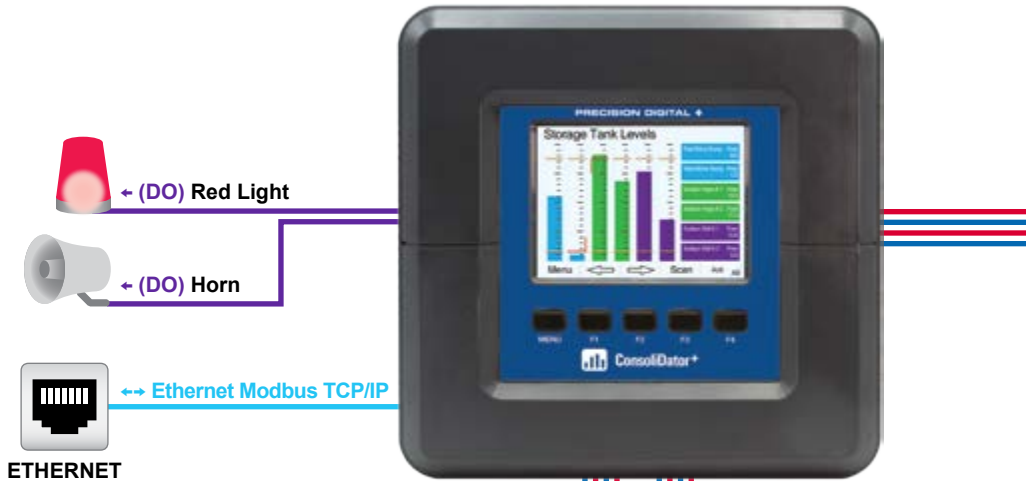

Model:
PD9000-GP-8AI-25RY-E

- Card 1: (4) 4-20 mA Inputs
- Card 2: (4) 4-20 mA Inputs
- Card 3: (5) Relay Outputs
- Card 4: (5) Relay Outputs
- Card 5: (5) Relay Outputs
- Card 6: (5) Relay Outputs
- Card 7: (5) Relay Outputs
- Standard: (4) Digital Outputs
- Optional: (1) Modbus TCP/IP

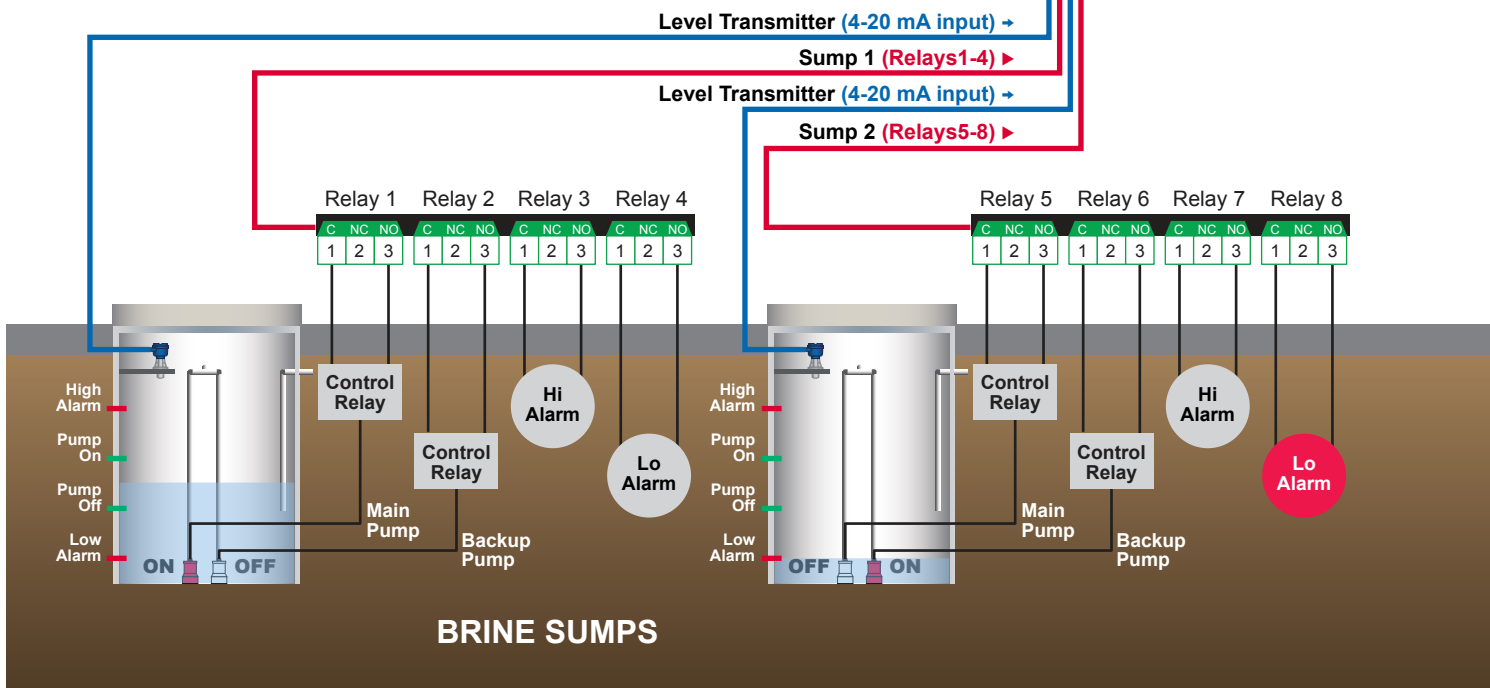

SODIUM BISULFITE STORAGE TANKS

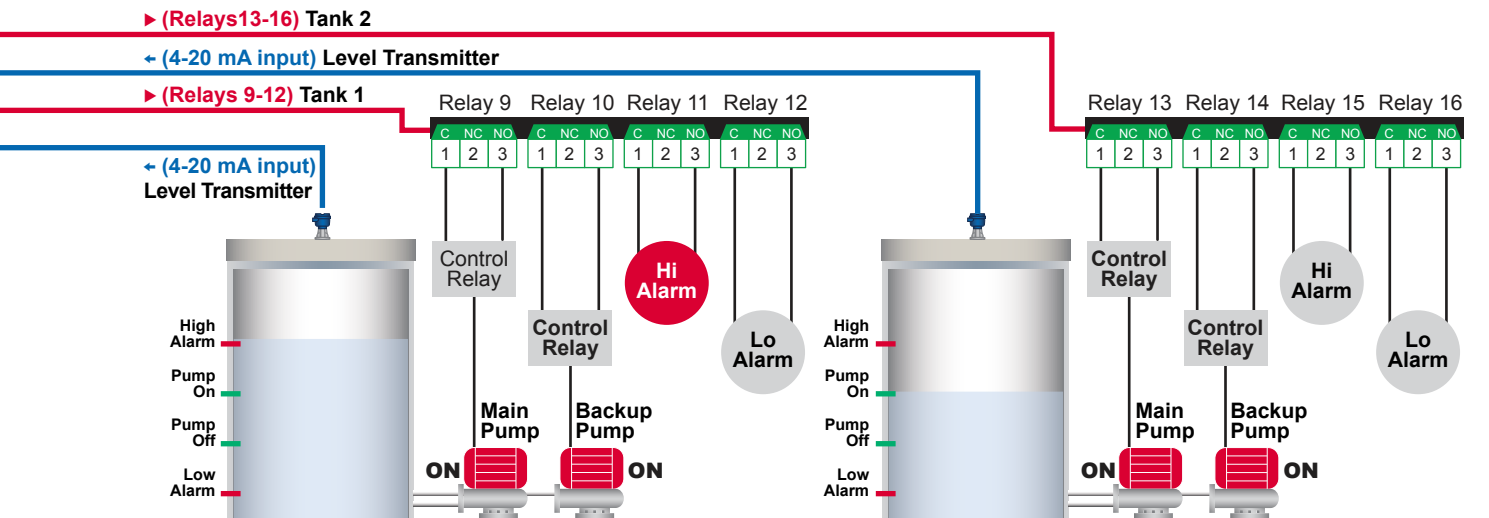
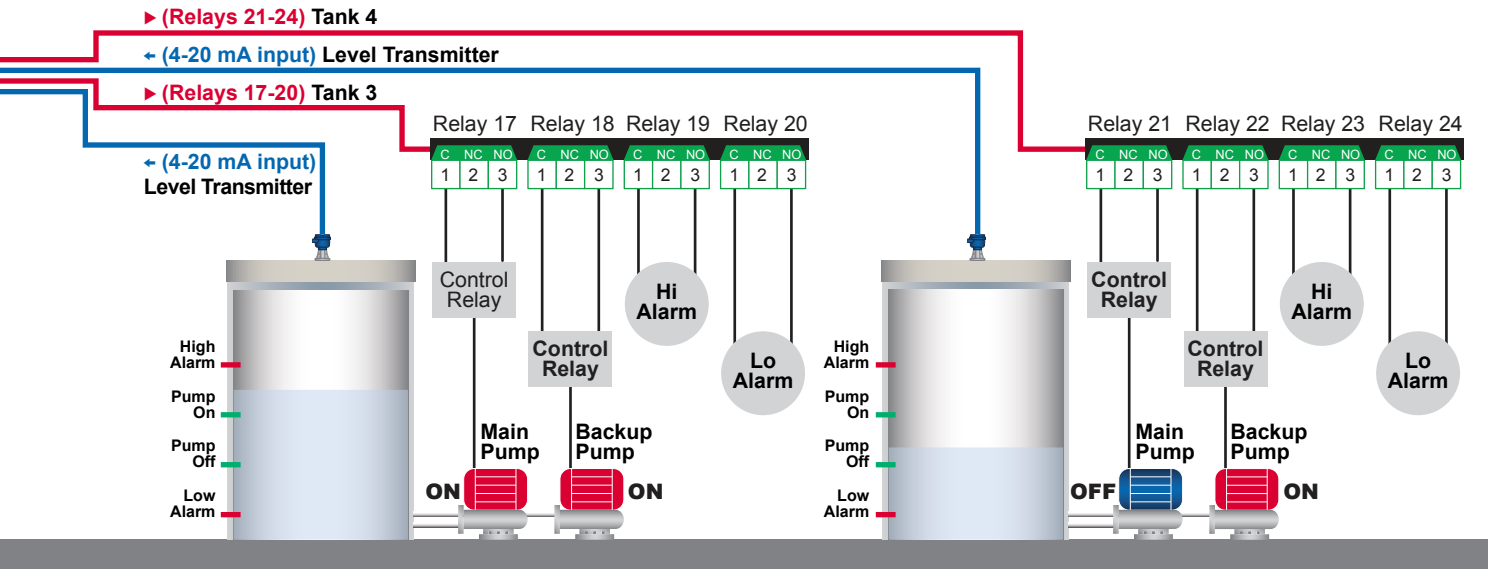

SODIUM HYPOCHLORITE STORAGE TANKS

Industrial Wireless

Point to Point Systems

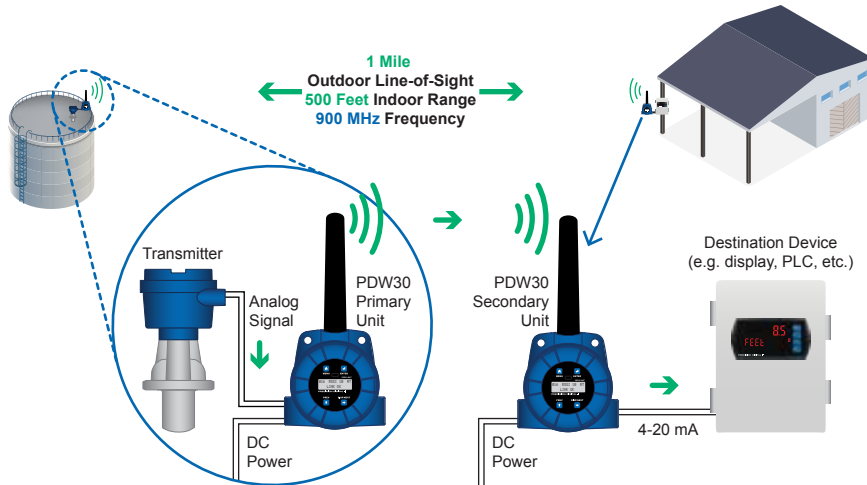

A Simple Wire Replacement Solution

The PDW30 is plug and play ready out of the box to wirelessly bridge a 4-20 mA signal. In addition, the PDW30 can transmit 4 digital I/O signals and RS-485 Modbus RTU.

Products

PDW30

Point to Multi-Point Systems

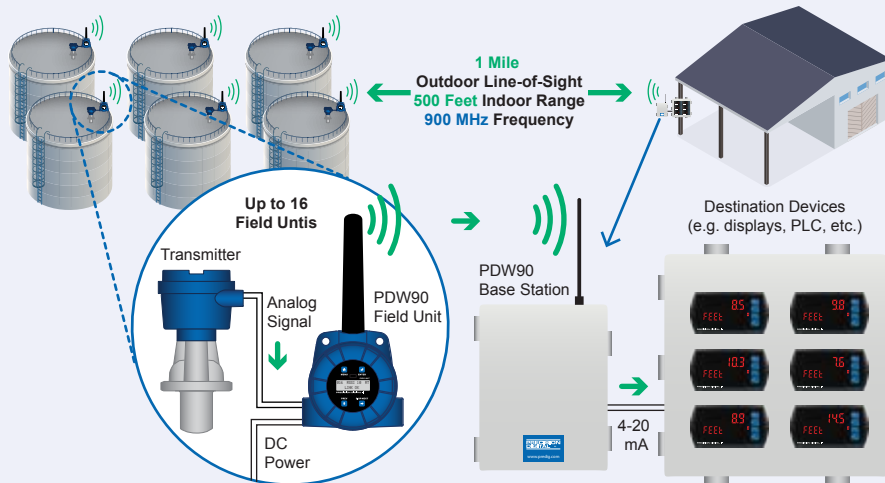

Connecting Multiple Devices Wirelessly

Wireless remote monitoring of tank levels is a great application for the PDW90. Multiple transmitters are outputting 4-20 mA signals to wireless field units. The 4-20 mA signals are being wirelessly broadcasted to the PDW90 base station which sends 4-20 mA signals to the destination devices. System supports up to 16 field units.

Products

PDW90

Make Your 4-20 Level Transmitter a Wireless Device

Application

A wastewater treatment plant was looking to get level readings from two level transmitters on top of two digesters back to a control room.

Challenge

Running signal wires from the two digester to the control room across a parking lot and road was not a feasible nor affordable solution.



Solution

The PDW90 point to multi-point wireless system was installed to get the levels within the digesters back to the control room. The level transmitter sends the signal to the PDW90-FN field unit, which sends that signal to the PDW90-BA base station located in the control room.

The PDW90-BA base station receives the signal and then retransmits the values to be displayed on two Loop Leader PD6602 loop-powered process meters.



Level

Powering Up the Transmitter

One of the most useful features found on all of our line-powered meters is a built-in isolated, 24 VDC power supply to power up the transmitter.

This feature saves money by eliminating the need for an external power supply. Plus, it simplifies wiring by reducing the number of devices in the loop.

Products

PD2-6000, PD2-6001, PD2-6060, PD765, PD6000, PD6001, PD6060.
Hazardous Area: PD8-765, PD8-6000, PD8-6001, PD8-6060.

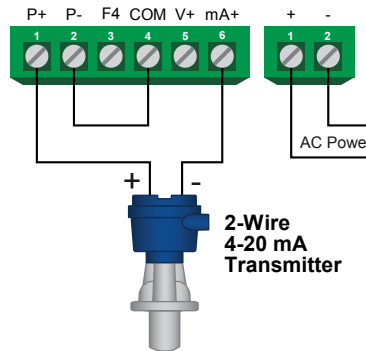

2-Wire Transmitter Connections

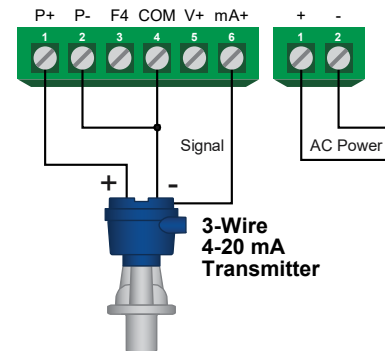

3-Wire Transmitter Connections (Provides up to 200 mA)

Pressure Transducers

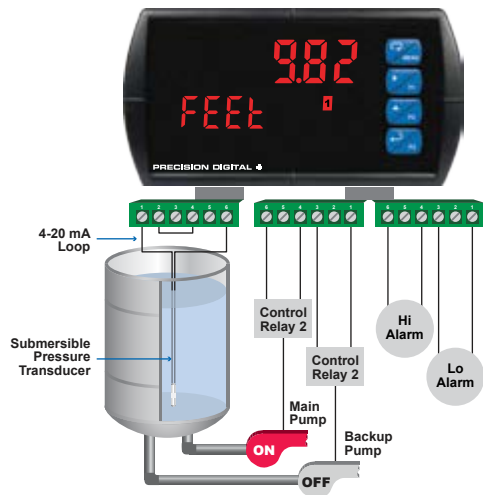

Submersible Pressure Transducer

Combine a Precision Digital meter with a submersible pressure transducer for a great way to measure and control level in a tank, sump, well, lift station, etc. Our meters provide power to the pressure transducer and relays for alarm and control.

Products

PD2-6000, PD2-6001, PD2-6060, PD765, PD6000, PD6001, PD6060. **Hazardous Area:** PD8-765, PD8-6000, PD8-6001, PD8-6060.

Point Level

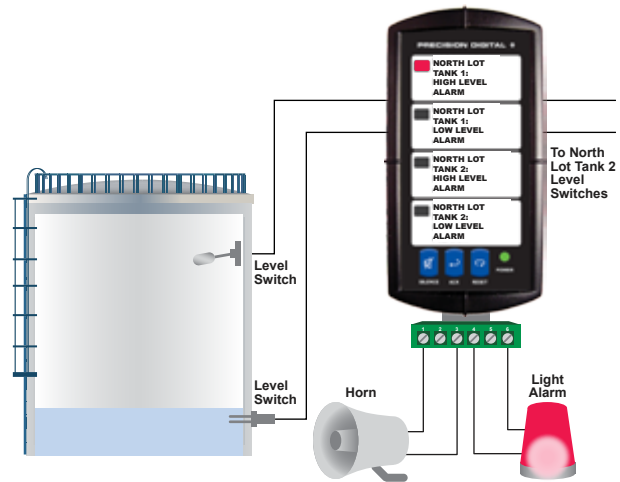

Level Switch Monitoring & Annunciation

Use our Vigilante 1/8 DIN or explosion-proof annunciators to indicate the status of up to eight level switches. Free custom labels, variety of alarm sequences, front panel Silence, Ack & Reset buttons and 2 relays to drive external devices like horns or lights.

Products

PD154, PD158. **Hazardous Area:** PD8-154, PD8-158.

Lead-Lag Pump Alternation Control

Many simple pump control applications don't require the sophistication and complexity of a PLC.

How It Works

The meter powers up the level transmitter. The meter displays the level in feet. Two relays are set up to control and alternate the main and backup pumps, while two other relays are used for high and low alarms.

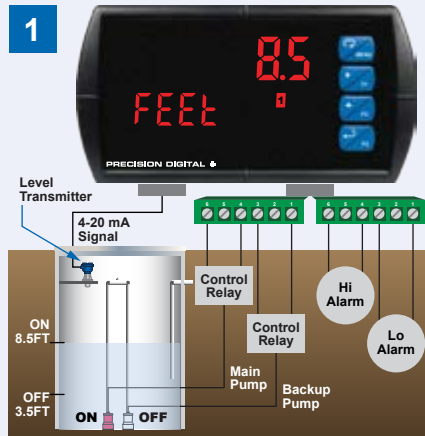

Relay #1 turns the main pump on at 8.5 feet and turns it off at 3.5 feet.

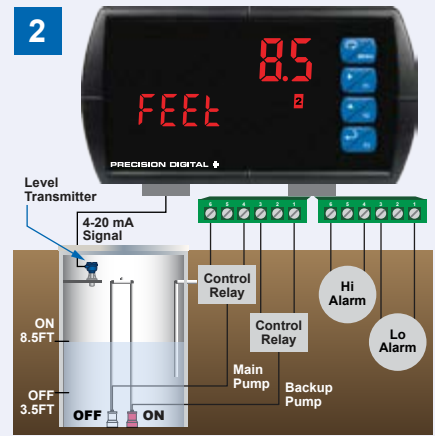

With the Pump Alternation feature activated, the next time the level reaches 8.5 feet, relay #2 transfers and starts the backup pump.

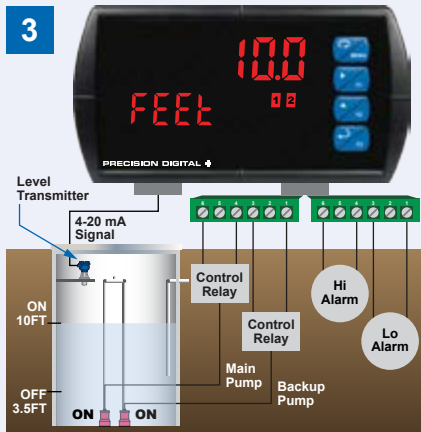

If the backup pump is not able to keep up, and the level reaches 10 feet, then relay #1 transfers and starts the main pump as well.

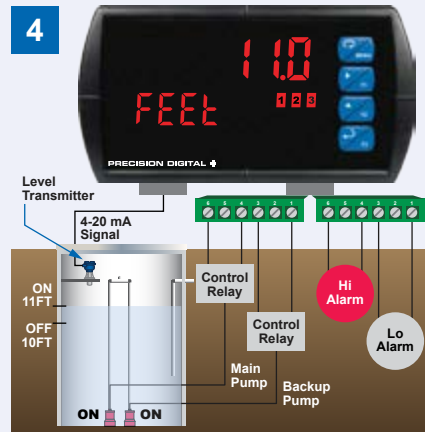

Relay #3 trips the High Level Alarm at 11 feet and resets at 10 feet.

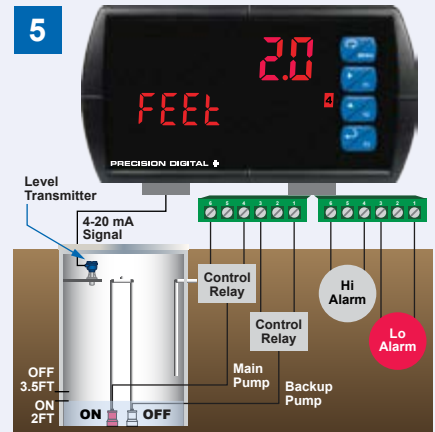

If the Main Pump fails to turn off, Relay #4 trips the Low Level Alarm at 2.0 feet to warn against the pump running dry.

Products

PD2-6000, PD2-6001, PD2-6060, PD765, PD6000, PD6001, PD6060, PD6602, PD6603, PD6604. **Hazardous Area:** PD6606, PD6607, PD6608, PD8-765, PD8-6000, PD8-6001, PD8-6060.

Dual-Scale Feature

This unique feature lets you display the measured input in two different ways. Both display lines are scaled independently and are based on the 4-20 mA input signal.



Gallons & Percent Full



Gallons & Height

Products

PD2-6000, PD6000, PD6602, PD6603, PD6604. **Hazardous Area:** PD6606, PD6607, PD6608, PD8-6000.

Tank Farm

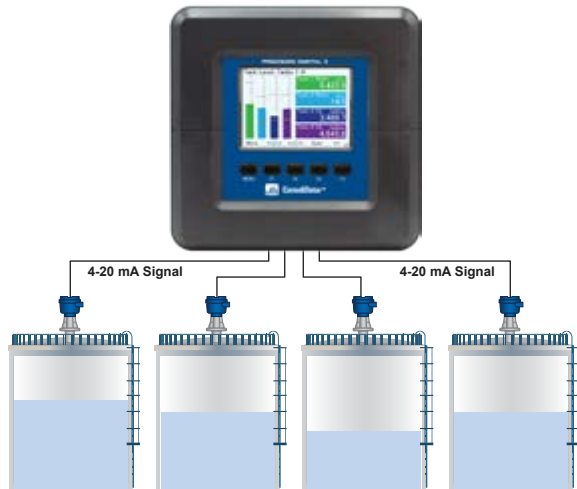

Level Monitoring of Multiple Tanks with ConsoliDator+

The ConsoliDator+ can display up to 8 tanks from 4-20 mA signals on a single screen. It may also be programmed to display up to 20 different screens in a variety of formats, colors, with and without bargraphs. Relays, 4-20 mA outputs, and Ethernet Modbus TCP/IP are available.

Products

PD9000

Level, Temperature & Interface

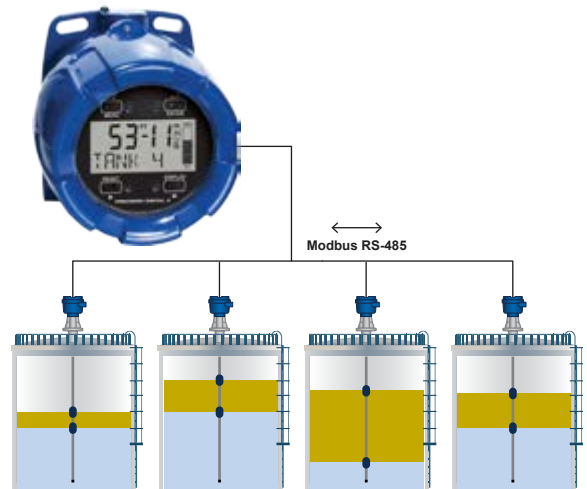

Modbus Scanner

Use our Modbus scanners to display level, interface level, temperature and other variables from multivariable level transmitters. Scan up to 16 Modbus process variables.

Products

PD2-6080, PD2-6081, PD6080, PD6081, PD6088, PD6089, PD6730X. **Hazardous Area:** PD8-6080, PD8-6081, PD6830X.



Hazardous Area

Hazardous Area Level Display in Tank Farm

The PD6801 displays level in feet and inches for those who prefer that format over decimal. It is loop-powered so no additional wiring or power is needed.

Products

PD2-6001, PD6001, PD6603, PD6701. **Hazardous Area:** PD6607, PD6801, PD8-6001.

Tank Height

Display Tank Height in Feet & Inches Outdoors Next to Tank

This Helios Large Display Meter is mounted high-up on a building next to the tank so it can be read from a distance. This particular Helios displays in feet and inches because that is how the customer is used to seeing their levels displayed. Line 2 can be programmed to toggle between units and percent full or volume if dual-scale mode is enabled.

Products

PD2-6001, PD2-6081, PD6001, PD6081, PD6089, PD6603, PD6701, PD6730X.

Hazardous Area: PD8-6001, PD8-6081, PD6607, PD6801, PD6830X.



Volume of Non-Linear Tanks

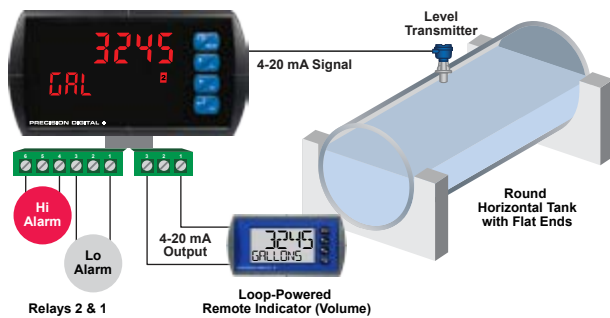

Round Horizontal Tanks

Automatically calculate the volume in a round horizontal tank with flat ends with the Round Horizontal Tank feature. Just enter diameter & length of tank and results are calculated in US gallons. For other non-linear tanks use 32-point linearization.

Products

PD2-6000, PD2-6060, PD6000, PD6060, PD6602, PD6604. **Hazardous Area:** PD6606, PD6608, PD8-6000, PD8-6060.

4 Ways to Display Level

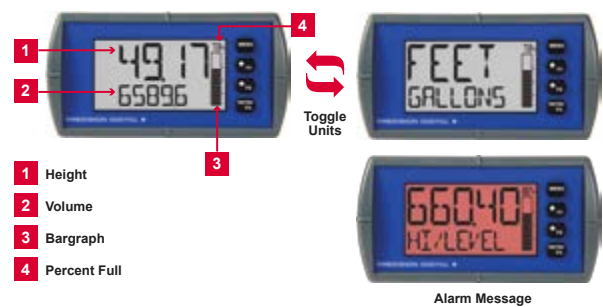

Dual-Line Bargraph Displays

Display line 1 indicates height, while display line 2 displays volume. The bargraph shows how full the tank is. The meter can also toggle between value and engineering units. Finally, the red backlight with a message flashes on alarm.

Products

PD6603, PD6604. **Hazardous Area:** PD6607, PD6608.

Flow

Open Channel Flow



Programmable Exponent Function

Using a level sensor to measure the height in a flume, the meter converts that signal to flow rate using the programmable exponent function. Simply input the corresponding exponent for the weir and the meter converts the signal to flow.

Products

PD2-6200, PD2-6262, PD6200, PD6262, PD6622, PD6624, PD6700, PD6720. **Hazardous Area:** PD6626, PD6628, PD6800, PD6820, PD8-6200, PD8-6262.

Differential Pressure Flow

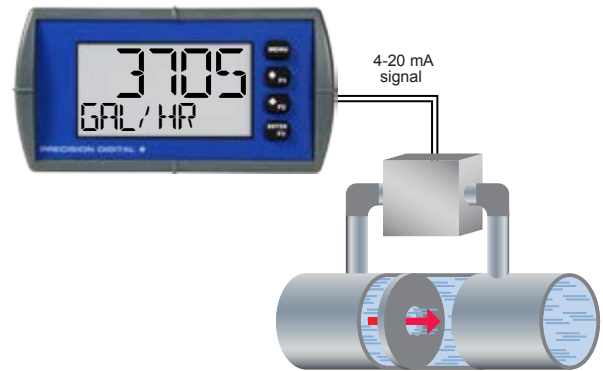

Square Root Extraction

Extract the square root from the 4-20 mA signal from a differential pressure transmitter and the meter displays flow rate. The user selectable low-flow cutoff feature gives a reading of zero when the flow rate drops below a user selectable value.

Products

PD2-6200, PD2-6262, PD6200, PD6262, PD6622, PD6624, PD6700, PD6720. **Hazardous Area:** PD6626, PD6628, PD6800, PD6820, PD8-6200, PD8-6262.

Display Rate and Total at the Same Time



Dual-Line Display

Makes it possible to show rate and total from a pulse or 4-20 mA signal at the same time. Grand total can also be displayed, plus engineering units.

Products

PD2-6200, PD2-6300, PD2-6262, PD2-6363, PD6200, PD6300, PD6262, PD6363, PD6622, PD6624, PD6720. **Hazardous Area:** PD6626, PD6628, PD6820, PD8-6200, PD8-6300, PD8-6262, PD8-6363.

Convert Pulse to 4-20 mA with PD6300



Pulse Converter

The PD6300 accepts the pulse output from a flowmeter and with the appropriate option installed can convert the pulse to a 4-20 mA signal. The 4-20 mA signal can be programmed to correspond to either the flow rate or the total flow.

Products

PD2-6300, PD2-6363, PD6300, PD6363, PD6730. **Hazardous Area:** PD6830, PD8-6300, PD8-6363.

Other Applications

Temperature



Pump Bearing Temperature Monitoring

The PD7000s monitor the bearing temperatures of six 250 hp intermediate pumps at a water treatment plant. Line 1 displays bearing temperature, and line 2 displays the high temperature alarm set point.

Products

PD138, PD2-7000, PD743, PD765, PD7000.
Hazardous Area: PD8-765, PD8-7000.

Gas Detection



Chlorine Leak Detection at Water Treatment Plant

Three PD765 Trident X2 displays are monitoring chlorine gas leaks from gas detectors located in various areas throughout a water treatment plant.

Products

PD765

Display & Alarm System

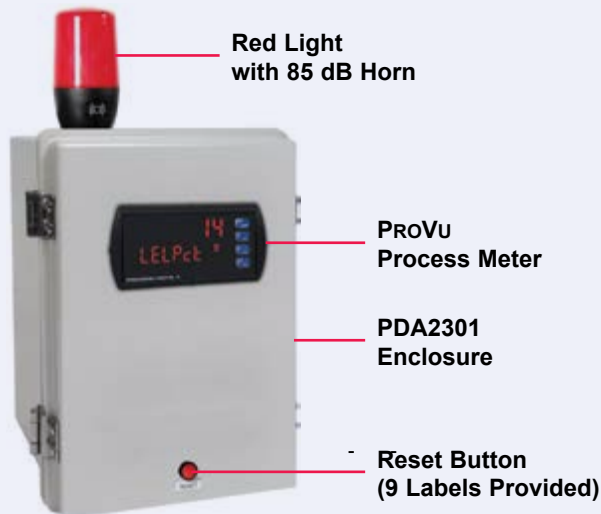

MOD-LH for Gas Detection

The PD6000-6R7 mounted in a PDA2301 enclosure with MOD-LHRB1 Light / Horn accessory makes a convenient display and alarm system for gas detection applications. For gas detectors that require more than the 200 mA power the PD6000 can provide, Precision Digital offers the PDA1024-01 1.5 A power supply.

Operation

Input: 4-20 mA = 0-100 LEL

Relay	Purpose	Trip	Reset	Action
1	Red Light	20	15	Latch
2	Horn	20	15	Latch w/ Clear
3	High Alarm to a Central Control System	40	35	-
4	Fault Signal to a Central Control System	-5	0	-

Products for the Water & Wastewater Industry

Digital 1/8 DIN Panel Meters



Trident X2

- Large 1.20" (30.5 mm) digits
- NEMA 4X front panel
- Sunlight readable display
- 24 VDC transmitter power supply
- 2 relays + 4-20 mA output



ProVu Series

- Dual-line, 6-digit display
- NEMA 4X front panel
- Sunlight readable display
- 24 VDC transmitter power supply
- Multi-pump alternation control
- 4 relays + 4-20 mA output



Loop Leader Series

- Loop-powered backlight standard
- NEMA 4X front panel
- 2 solid state relays + 4-20 mA output
- 2 open collector outputs standard
- 1.5 V drop (4.7 V with Backlight)
- Pump alternation control

Multivariable Controllers



Consolidator+ Series

- NEMA 4X panel mount
- Display, control, & alarm of multiple 4-20 mA & pulse inputs
- Sunlight readable color display, white backlight
- 24 VDC transmitter power supplies for all analog inputs & outputs
- Multi-pump alternation control
- Power of a PLC & HMI with the ease of use of a panel meter

Large Display Meters



Helios Series

- Great for outdoor applications
- Large 1.8" (46 mm) digits
- Superluminous display
- On-board USB programming software
- Satisfies multiple applications

Industrial Wireless Systems



PDW30 & PDW90 Wireless

- Point to point or multi-point signal wire replacement
- 1 mile line-of-sight, 500 ft indoor range
- Software available for easier setup
- PDW30: Inputs and outputs on both field units
- PDW90: Connect up to 32 field units and up to 16 expansion modules

Field-Mount Indicators



Vantageview Series

- 4-20 mA input, loop-powered
- Dual-line display
- Plastic NEMA 4X / IP65 enclosure
- SafeTouch thru-window buttons
- Flanges for wall or pipe mounting
- Backlight standard
- 3.0 V Drop (6.0 V with Backlight)

Order from: **C A Briggs Company**

622 Mary Street; Suite 101; Warminster, PA 18974

Phone: 267-673-8117 - Fax: 267-673-8118

Sales@cabriggs.com - www.cabriggs.com

LMDWWSG_B 01/21



www.CABriggs.com